

CONNOISSEUR MODELS LMS FOWLER 4F 3500 GALLON TENDER

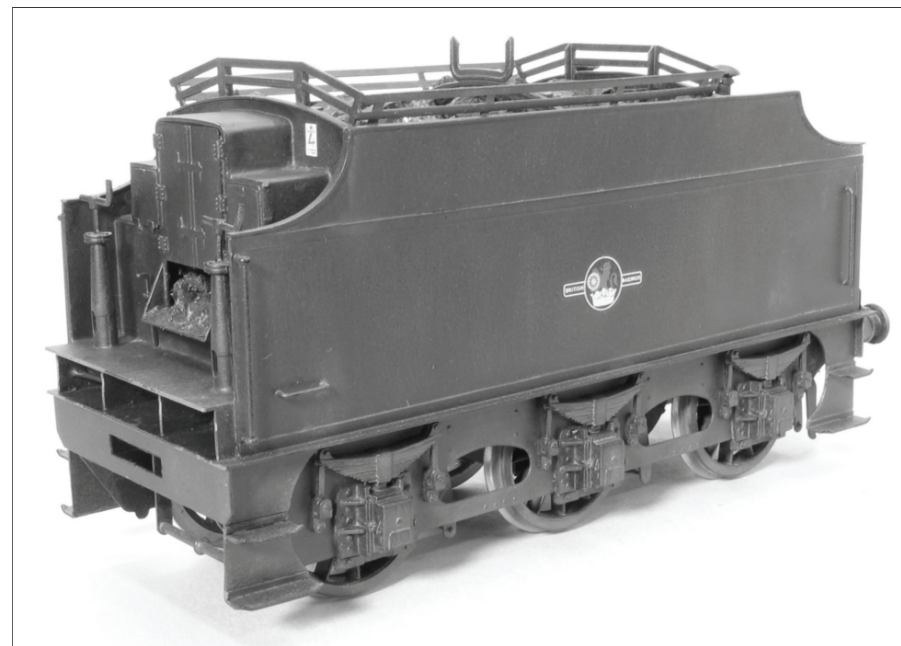

This kit has been designed to provide a set of quality components that will allow the modeller, who has basic kit building skills, to build an O gauge model of the prototype to a standard of detail that is suitable for operating models on most O gauge layouts.

It is not intended to be a state of the art kit, though those who wish to upgrade their model through the substitution of various fitting and by fabricating some of the smaller supper detail parts, can lift it into the showcase class with the kit providing an accurate and economical base on which to work.

With these kit instructions I have assumed that you have already built a simple tank loco and are familiar with basic loco kit building skills. The instructions are intended to show clearly when and wear to fit a part but do not deal in depth with construction techniques. If you are a little unsure of your skills I would suggest building the tender first.

Wheels, 3 Sets 4'3", 12 Spoke (Slater's Cat No 7851)
Are Required To Complete

GENERAL INSTRUCTIONS

Please read this section carefully especially if this is your first etched brass kit. Many modellers fight shy of working in this medium but the basic skills are relatively easy to acquire. Once you've learned how to form and solder brass you'll find all kinds of modelling possibilities will open up for you.

Assembling an etched kit involves exactly the same skills that a scratchbuilder uses – the only difference is that the cutting out of the parts is already done for you. Some filing and trimming will be necessary from time to time. Where this is the case I have highlighted it in the instructions.

The main skill to master is soldering and I would recommend a Weller 40 Watt soldering iron. This has a 6mm diameter removable copper bit. The bit is shaped like a screwdriver and has a bright coating of solder (tinned). This combination of iron and bit shape is ideal for running fillet joints and has a good reserve of heat that is so necessary for soldering small parts onto large components. Note the shape and condition of a new bit as this won't last long and will need restoring back to this condition.

It is important to keep the bit clean and in good condition as you work. Get a soldering iron stand containing a damp sponge as old oxidized solder is wiped off on this before picking up fresh solder for each joint. If you haven't made a joint for some time you may find that a hard black crust has formed on the bit. Remove this with a brass wire brush (suede brush) and then feed some multicore solder onto each side of the bit to restore a bright surface (referred to as wetting or tinning the bit). After about 8 hours use you will find the bit is in poor condition with holes and a ragged edge. File the bit back to its original shape using a hand bastard file and then polish the surfaces on emery cloth. Coat the bit with Fluxite Soldering Paste (traditionally used by plumbers) and this will prevent the bare copper oxidizing as the iron heats up. Then feed multicore solder onto the bit to form a generous coating and leave to bubble away for a couple of minutes before wiping the excess off to give a bit almost as good as new.

A smaller Antex 25 Watt iron with a 3.2mm screwdriver bit is very useful for small assemblies and detail work such as handrails, but will have insufficient heat reserve for main assembly work. The Antex has a plated iron bit and after a little use with 145° solder a grey oxide appears on the bit that will prevent you from picking up the solder. Touch the bit to some multicore solder and it will flash over the bit wetting it so that you can continue picking up 145° solder. I have found no problems with mixing the two solders in this way.

I use 145° solder for virtually all assembly work. I prefer it in wire form, available from many tool merchants, but it is also produced in stick form by Carrs. I find that its lower working temperature helps to give a quick clean joint and limits the build up of heat which may cause distortion in components. I find that I can hold parts together with my finger ends and make a joint before heat reaches my fingers or other etched parts drop off.

I use 60/40 tin/lead fluxed multicore electrical solder (melting point about 190°) mainly to keep the iron bits in good condition. As it gives a slightly stronger joint

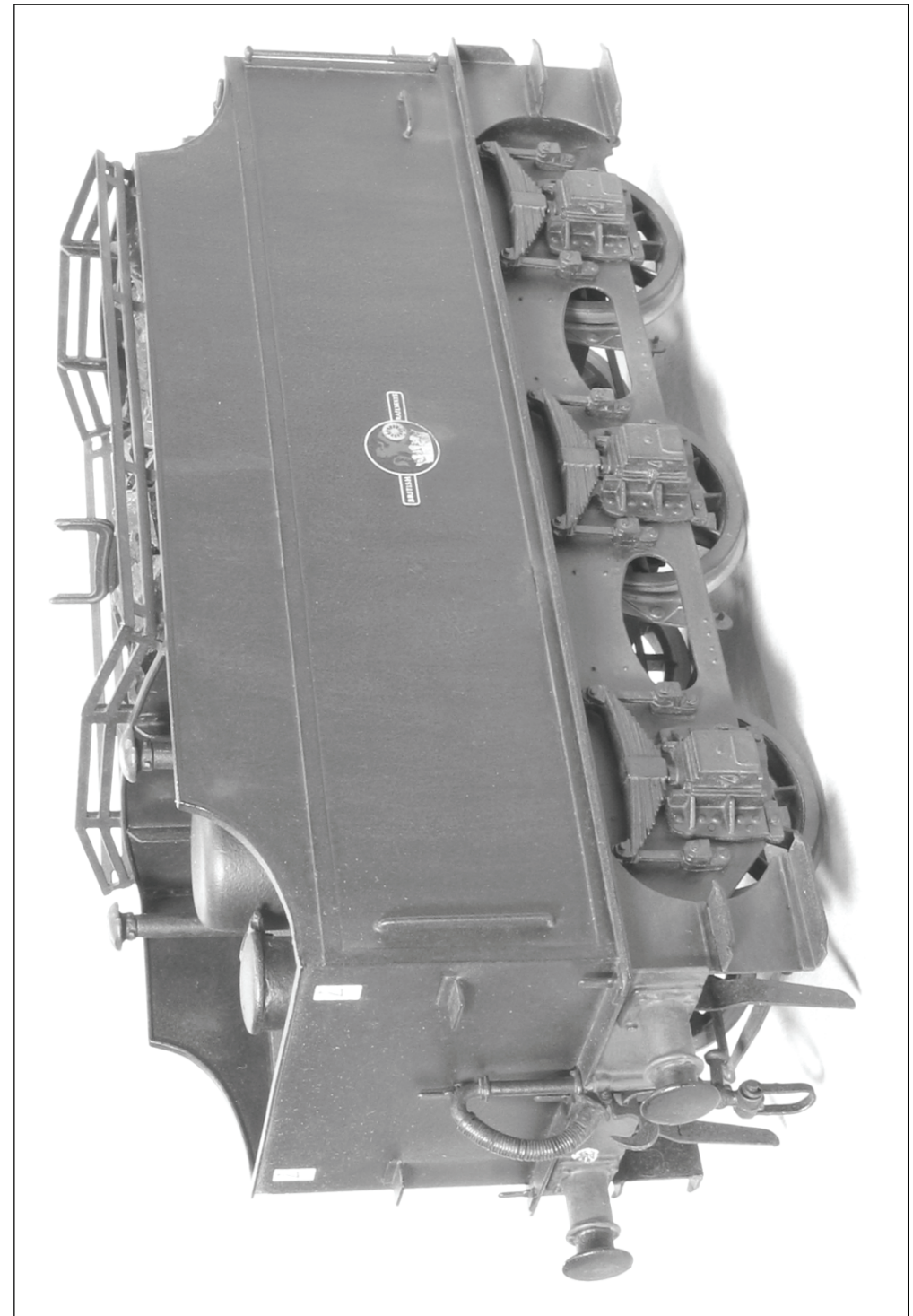

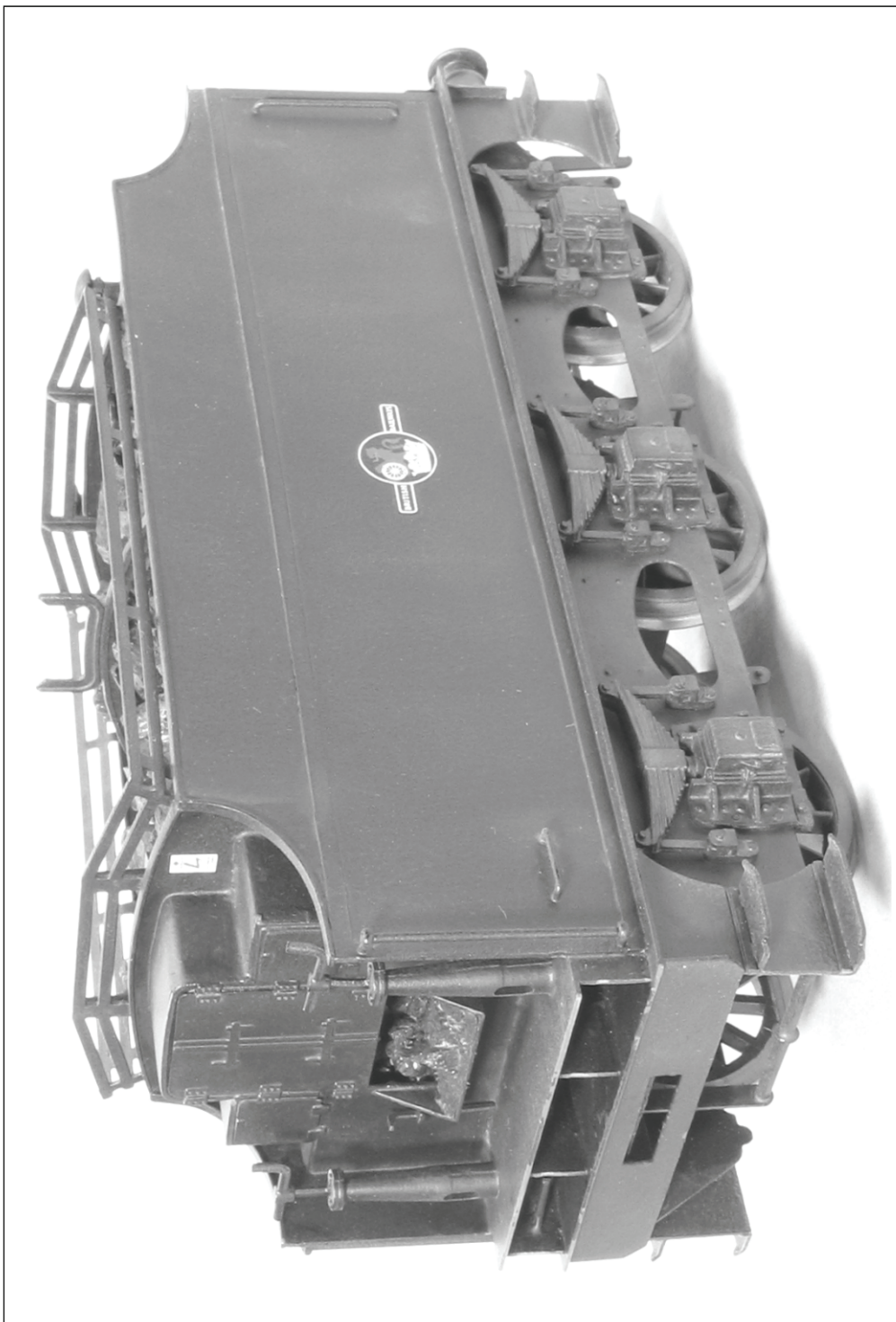

than 145° I sometimes use it for small spot joints on handrail wire, lamp brackets etc, but still use extra liquid flux.

For all brass and nickel silver work I use Carrs green label liquid flux. You will soon get the feel for how much to use but more problems are caused by too little flux than too much.

Before soldering components together thoroughly clean both surfaces along the join line with a glass fibre burnishing brush. Using your tweezers or a knife blade etc, hold the parts together in the correct position and with an old paintbrush run some flux along the area to be joined. Still keeping the parts correctly aligned, pick up a small quantity of solder on the tip of your iron and carry it to the joint (unlike electrical soldering when you feed solder into the joint). Hold the iron against the joint just long enough for the solder to flash between the parts. Don't let go of the parts until the solder has cooled – this takes from five to ten seconds. To run a fillet of solder along a joint, wait until the solder flashes between the parts and then pull the molten solder along the joint with the iron tip. Don't load the iron tip with a lot of extra solder work the joint in 1" lengths bringing in small quantities of solder.

Brass is a very forgiving material and if you get something out of alignment use heat from the iron to desolder the joint before starting again. For complicated assemblies it is a good idea to only tack solder parts together. You can then make adjustments by desoldering until you are happy with the location of parts and then solder solid.

When you need to laminate two or more layers of brass together align the parts then carefully clamp them together either in the vice or by holding them with miniature crocodile clips. Run flux around the edges and then go around with the soldering iron. Clean up thoroughly afterwards.

To fit small parts and overlays on to a larger assembly, such as strapping to a wagon side, when you need to prevent finely detailed areas such as planking becoming clogged up with solder tin the back of the small component first, then hold in place on the model and apply flux. Carefully wipe the tip of your iron on a sponge to remove any solder from it (dry iron), and then touch it against the parts to be joined. After a few seconds you'll see molten solder bubbling from the edges. Still holding the parts in place remove the iron and allow the joint to cool. An alternative is to use solder paint (I would recommend Carrs 188 solder paste). As the name suggests this is a flux and solder in one. Simply apply a thin coat of solder paint to the back of the component instead of tinning. Still apply a small amount of liquid flux before you solder the part into place.

Any surplus solder should be removed using a craft knife, I find No 10 curved scalpel blades ideal, then burnish clean with a glass fibre brush. With practice you'll learn how to use the minimum amount of solder to do the job. Flux is corrosive so after each soldering session give your model a good scrub with washing up liquid or Jif. After a day or two any remaining flux residues will show as a green film which should be washed away.

To cut parts from the fret use a sharp Stanley knife on a piece of hardboard or a pointed scalpel blade on a block of softwood. Remove tags and burrs with a fine file.

Three-dimensional parts are formed by folding. On an etched brass kit the fold lines are normally half-etched on the inside of the fold. You'll be able to fold most parts using smooth-jawed pliers. For longer parts folding bars are desirable.

Other useful tools include a bench vice, a good pair of tweezers, a set of Swiss files (get a full set of cheap ones and then buy quality replacements for the three that you use the most), a pin vice with a selection of drills from 0.5mm to 2.1mm plus a few larger sizes that you use regularly (2.6mm for axle bearings etc), some square-nosed pliers and some very pointed-nosed ones, preferably with smooth jaws. Buy cheap tools first and duplicate the most used ones with quality.

Try to complete all high-temperature soldering before attaching any of the cast whitemetal parts. These can be attached with two-part epoxy resin such as Araldite Rapid. Ensure the surfaces to be glued are clean and free of grease.

A better alternative is to solder your white metal castings using Carrs 70 degree low melt solder and Carrs red label white metal flux. The iron should be run at a much lower heat so that you do not melt the castings. I have a domestic light dimmer switch and plug socket fixed to a piece of wood, wired up with a lead and standard mains plug fused at 3 amps to the input side of the dimmer switch and the output of the dimmer switch into the plug socket (remember to continue the earth). Plug your 40 Watt iron (25 Watt iron won't work) with a clean and freshly tinned bit into this and experiment with adjusting the switch until you find the range of temperature at which the solder melts but a scrap casting does not. Note as the iron is running at a lower voltage it will take longer to heat up, so when you think the adjustment is correct do check a few minutes later on another scrap casting to see that it doesn't melt. Then scribe a mark on the switch knob to indicate this position.

When attaching white metal fittings to brass the surface of the brass must be tinned with 145° solder to allow the solder to grip. The surface of the casting at the joint should be burnished bright. The casting can then be soldered into place with 70° solder and fillets of solder run into any gaps with no risk of melting the casting. Virtually all castings will be improved by a little extra fettling work. Flash can be cleaned out using a sharp pointed knife blade, part lines removed by scraping back with a curved blade and then blending in using a fibreglass brush. The casting moulds tend to distort when metal flows in so check castings for square and even thickness.

SPECIFIC INSTRUCTIONS FOR LOCOMOTIVE KITS

Hole Sizes. Because of the etching process holes will normally be found undersize, for example the turned brass bearings will not fit holes in chassis sides, and a simple fitting operation is required. The best tool for opening up holes of this size is a cheap tapered reamer available at most model railway shows from tool suppliers. By rotating this gently in the hole you quickly open holes to correct size without risk of tearing the metal. By trial and error on the first hole you will soon establish how much material requires removal. For smaller holes, such as those for the location of casting's etc, are best opened up using a set of cheap tapered broaches, or by twisting a small round file in the hole.

The chassis is fixed to the body using two 6BA screws into the captive nuts that you soldered to the footplate as one of the first operations. No matter how careful you are in building the tender body you will probably have built in a slight twist. It is important that the body does not twist the level chassis out of square so I recommend only locking tight one screw leaving the other slightly backed off.

9. Painting is a vast subject that cannot be covered fully here. The important thing with a metal model is to get a good base coat of primer. Hopefully you have been cleaning up and washing the model at the end of each modelling session but it will still need thoroughly cleaning before painting. I give my models a good scrub with a stiff-bristled paint brush in a sink full of hot water, as hot as your hands can bear, and cheap washing up liquid (the expensive stuff that's kind to your hands has an oil in it that will stop the paint keying to the metal). If you know somebody who works in catering and can scrounge you some industrial-strength liquid this is better still. Then rinse the model a couple of times in clean warm water and place in a dust-free box to dry. I use car aerosol primer and Halfords grey primer is one of the best. For the best results you want to spray at room temperature (25°C) on a dry day, avoid cold, damp or humid days. I find it helps to warm the model to about 30°C (put it in the airing cupboard overnight) and I warm up the paint tin by putting it onto a radiator (about 40°C, but use your common sense as I don't want anybody blowing themselves up). I find it best to prime the model in two light coats, about 15 minutes apart and then leave for 48 hours to harden off (in the airing cupboard in a dust-free box).

I brush-paint my models with Humbrol enamel. For years I just stirred it up and painted straight from the tin but I was never completely happy with the results. Recently two things have transformed my painting. The first was a copy of Martyn Welch's book, *The Art of Weathering*, Wild Swan Publications, ISBN 1 874103 11 9. Martyn's basic techniques are very useful and almost foolproof. The second thing is to mix the paint in the tin and then transfer it to a palette (a sheet of clean plasticard) with blobs of lighter and darker shades of paint surrounding the main colour. Then work the paint with the brush on the palette, slightly varying the tones of the paint. This seems to totally change the texture of the paint and the way it goes on and covers on the model.

Can You Help Me?

If you have enjoyed building this kit and have been satisfied with the quality, I would be most grateful if you could recommend it to your friends and fellow modellers. Although my kits are not perfect, I try to put a lot of time and effort into producing them. If I can get extra sales of a kit through customer's personal recommendation and I find that word of mouth is the best form of advertising. This will help me to put extra time and money into developing the next kit. Hopefully this will give me more satisfied customer to recommend my kits to their friends.

If you are not happy with this kit then please tell me. Hopefully I will then be able to help and sort out any problem.

Best Regards And Happy Modelling

Jim McGeown

Page 17

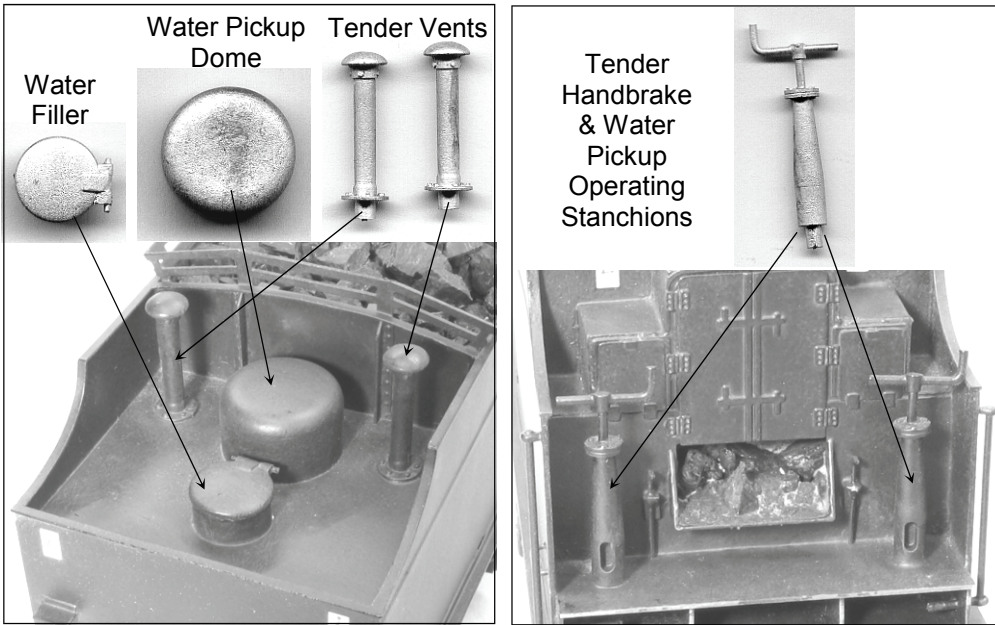

Loco to tender coupling bar (part 103). This can be used in two ways, if you prefer to have your loco and tender permanently coupled you can solder nuts to the loco and tender chassis. Then couple up from underneath by passing screws through the holes in the coupling bar. The screws need to be backed off slightly to allow the bar to swivel freely. Smear the ends of the screw threads with a little Evostick to prevent the screws working free during running but if you need to uncouple again a sharp turn of the screwdriver will break the bond and allow the screw to be removed.

If you prefer to frequently uncouple the tender by simply lifting it off the coupling bar then solder a screw into the tender chassis to form a peg. The coupling bar can be permanently screwed to the loco (see loco instructions) and the tender coupled by engaging the peg into the hole in the coupling bar. A short section of the tender front buffer beam below the slot will require cutting out to enable the tender to be lifted off the coupling bar.

The coupling bar has two sets of holes set at different centres so that you can couple the tender at prototype distance or slightly wider depending on how tight the curves are on your layout.

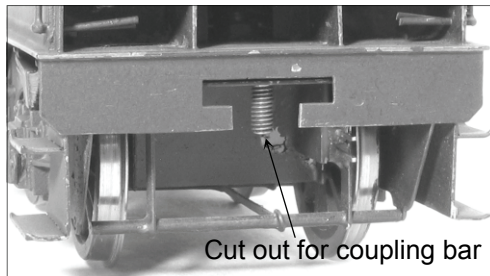
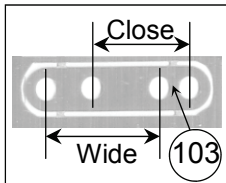

That should be the physical construction of the tender completed. One alternative that you may wish to consider is to fit additional tender pickups. Particularly if your layout requires a lot of reliable slow speed running so I have included details of how I fitted tender pickups to give you inspiration.

Forming Parts. While the boiler in this kit is pre-formed, other forming is best achieved as construction progresses as this enables the parts to be adjusted to each other. To make a tight curve at full metal thickness, such as tank front, bunker rear etc, take a piece of rod slightly under size of the curve required (a drill shank is ideal). Place roughly on centre line of bend holding in place with thumbs and pull upwards with fingers forming approximately 30 degrees of the bend. Check with eye and adjust if necessary before forming 60 degree of bend then offer part to model. Final adjustment of fit is easily made on last stage of bending.

To form shallow curves, splasher tops, smoke box wrappers etc, use a piece of pipe or broom handle. Diameter is not crucial, a piece of one-inch water pipe covers cab roof to smoke box wrapper. Place part over tube and hold in place with finger and thumb of one hand. Work the metal in stages over tube with finger and thumb of the other hand until correct radius is formed.

A technique you may find useful in working metal is to soften and remove the spring from the metal by heating (called annealing). The part is held with pliers and heated in a gas flame. (The gas cooker is ideal). Alternatively use a pencil torch that runs off lighter fuel. Heat part until a purple band appears close to the edges and then remove from heat. Do not overheat part as it will then become too soft and unworkable. Remember you can reheat if not workable. Allow part to cool naturally in the air.

Damaged Parts and Shortages. If you damage an etching during construction it is not possible to replace individual pieces, but I am quite flexible in providing at minimum cost replacement frets (this will contain all the brass or N/S parts). Where a casting is damaged individual items can be replaced as I have full control of production. Because of the complexity of the product, combined with the low volume way it is produced, I try to exercise a high degree of quality control in production and packing but if you find you are short of an item or find a sub standard part please approach me for a replacement.

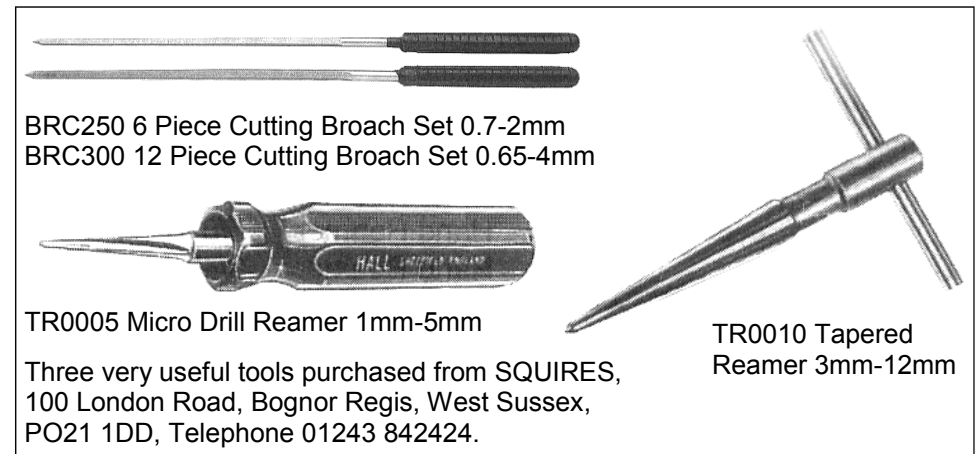

TENDER SUPERSTRUCTURE ASSEMBLY

Parts are numbered in a logical assembly order. The slots and tabs don't give accurate location, they are only there to help position parts. Tack solder a part into place then adjust the next part to match. Solder solid only when happy with the assembly. I have tried to mark the etchings and provide location slots so that the positioning of parts is obvious without the need to constantly refer to complex exploded drawings. If you are a little uncertain about the positioning of a component from reading through the instructions don't worry as this should become obvious as construction progresses and most parts if offered up to the assembly will only fit into the correct place.

1. Take the footplate (part 62) and solder two 6BA chassis fixing nuts to the top side. This is best achieved by locking the nuts in place with the screw, remember to put a spot of oil onto the thread to prevent soldering everything solid. Then take the tender sides (parts 63) and fit the side beading strips (parts 64). This is best achieved with the tender side placed on a flat surface. The full metal strip on the beading is designed to fit into the etched grooves on the tender sides to aid positioning and help to get the strips straight. Fit the bottom length first then the two end uprights followed by the top strip. Then fit the two tender sides into the footplate slots making sure that they are straight and parallel to the footplate edge and are square and upright. Check with an engineers square that the two sides are exactly opposite each other.

2. Fit the tender back (part 65) so that it fits snugly into the etched rebates on the inside face of the tender sides. It may be necessary to file the side edges of the tender back slightly to achieve a snug fit. Take the centre support (part 66) and fit between the tender sides locating into the footplate slots. Again it may be necessary to file the sides to achieve a snug fit and ensure that fitting the support does not push the tender sides out of square.

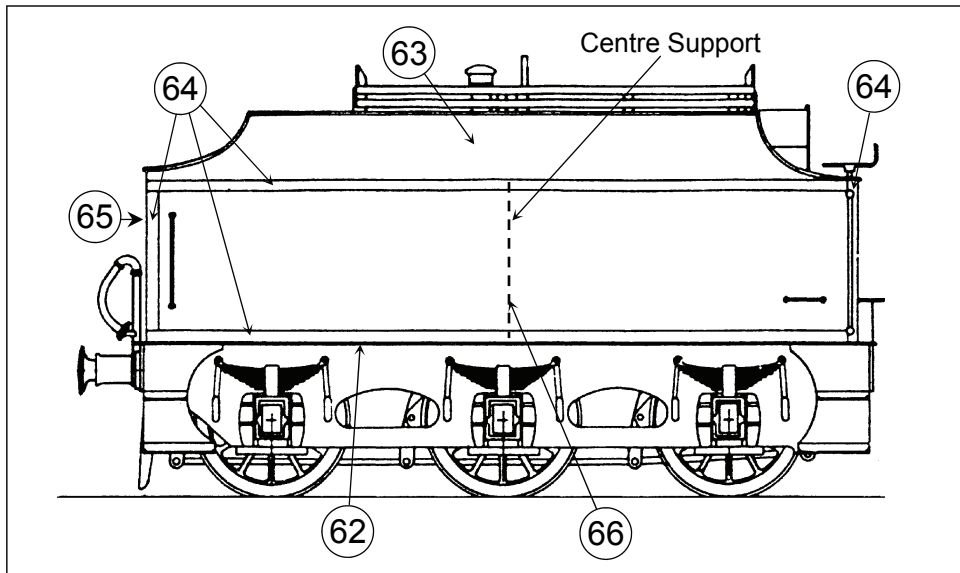

8. We are now down to the detailing and fitting of the castings. I leave these to this stage so that they won't get damaged with the repeated handling of the main construction. These parts can be fitted in whatever order takes your fancy but I tend to fit the parts that require higher temperature soldering first. First the handrails then the lamp brackets and then the coupling. Then I fit the castings.

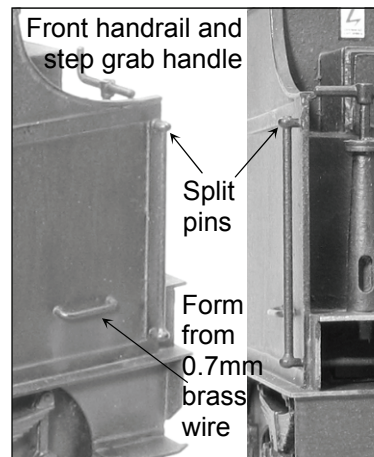
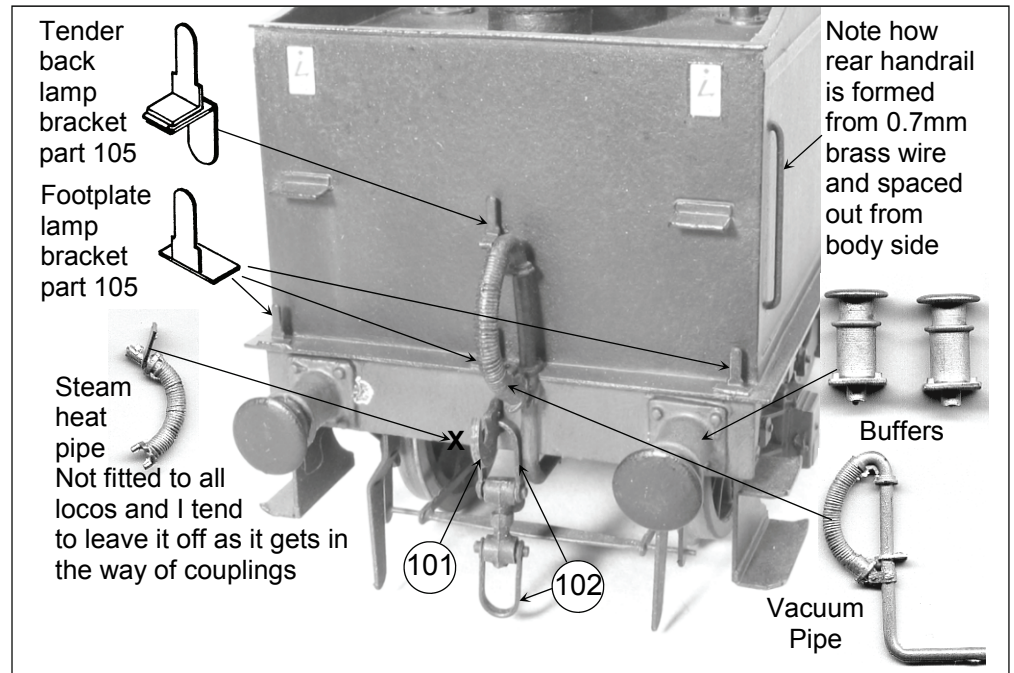

The handrails are formed from 0.7mm brass wire. Only the front handrails were supported by any form of handrail knob and even if you normally use handrail knobs I would recommend using the split pins as they better represent the prototype supports.

Cosmetic screw coupling. Solder both halves of each hook (parts 101) together and if necessary round the slot so that the link will swing freely and then using round-nosed pliers form the four links (parts 102) into U shapes. Dress the tops of two links with a file so



that they will pivot freely in the slot in the hooks. Thread one of these links through the hook and spring the ends over the pegs on the cast centre. Then fit the bottom link. Pass the coupling hook through the slot in the buffer beam, I solder it solidly into place but you can retain it with a spring if you wish.



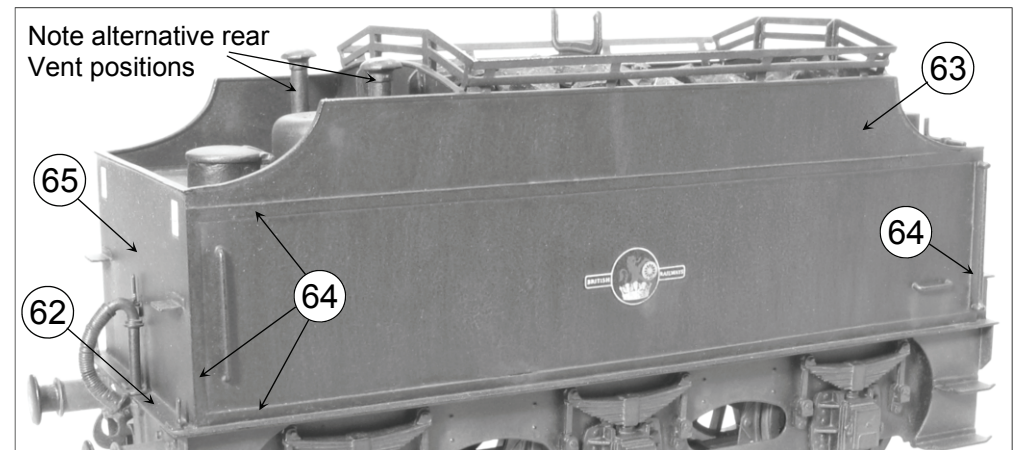
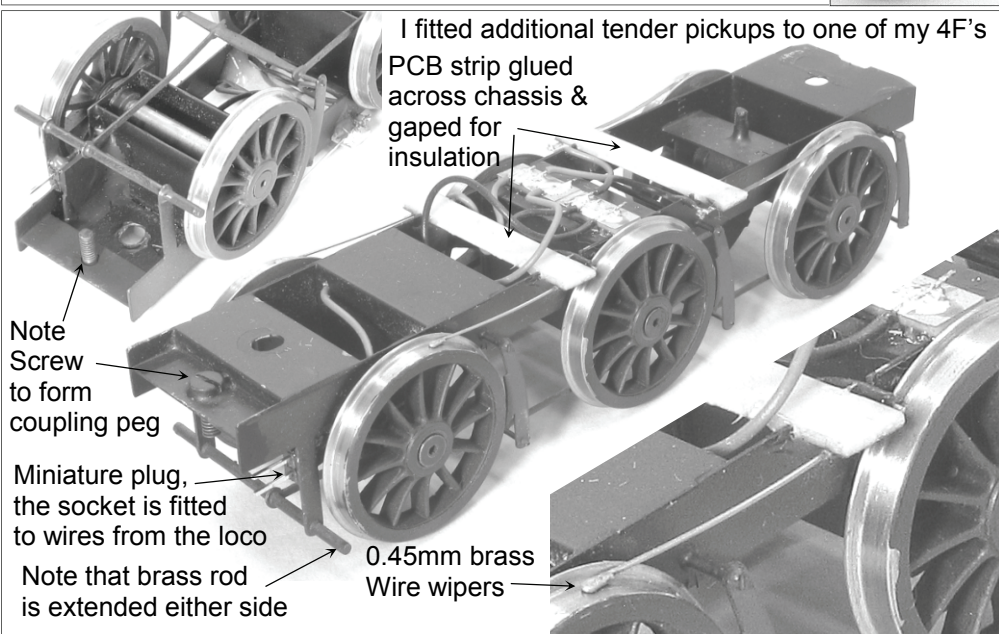
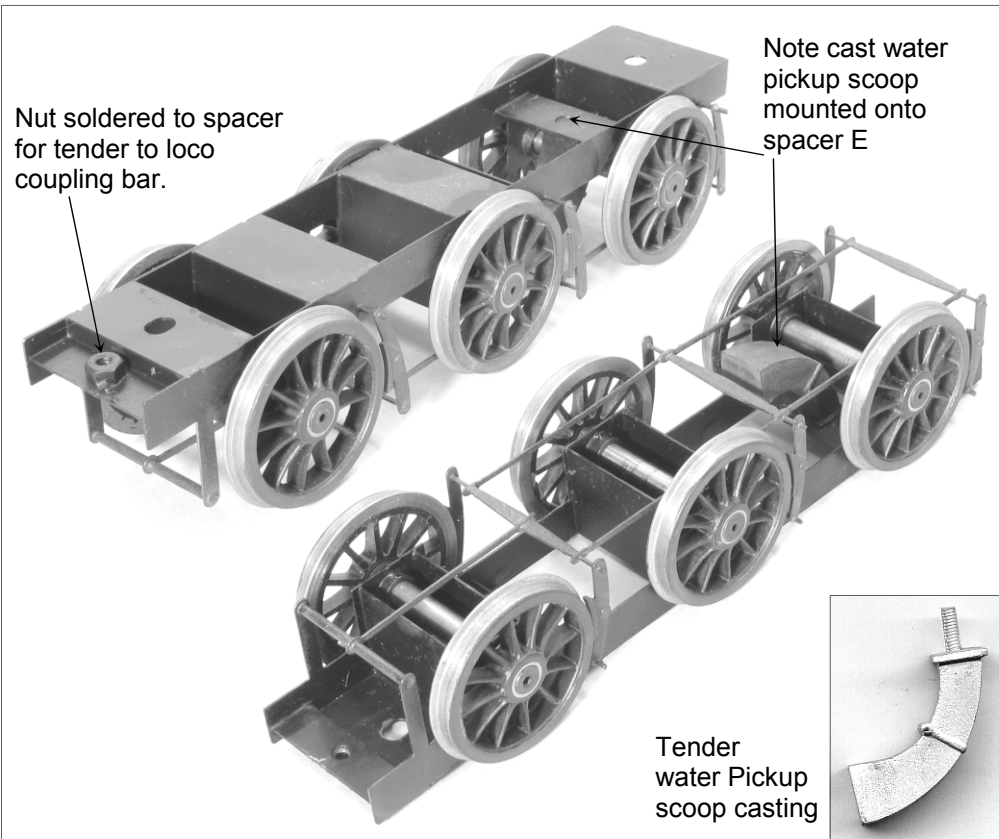

3. Take the tender top (part 67) and note that there are two alternative positions for the tank vents and these positions are marked on the underside by half etched holes. Decide in which position you wish to have the vents and then drill out the relevant holes. As a rule of thumb early locos without coal rails had the vents inside the coal space, later when coal rails were fitted the vents were moved towards the back of the tender, but you can find photos that disagree with this. So check a photo of your chosen prototype.

Now take the coal space hopper (part 68) and fold up to shape but don't solder the joints yet. The idea was that you soldered the hopper to the tender top and this set the tender top at the correct slope and the assembly could be dropped straight into place but I didn't get the angles correct. I found that it was just as easy to fit by bodging than if I had got it right so this is what to do.

Tack solder the back edge only of the coal space hopper to the tender top. Now fit the tender top into place soldering to tender back and centre support. Fold down and solder the tender top side pieces to the tender sides at a distance of 21mm from the top of the tender side. Once these side pieces are soldered solid you can snip out the strengthener strip at the front end.

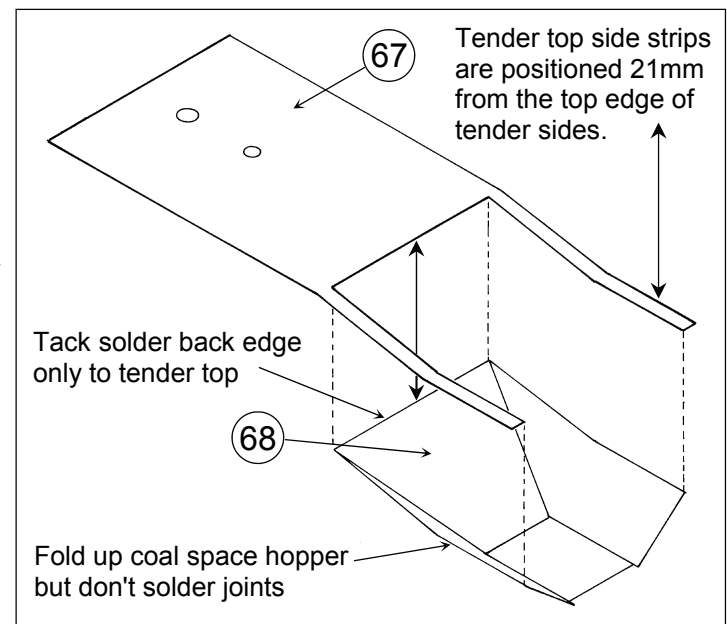

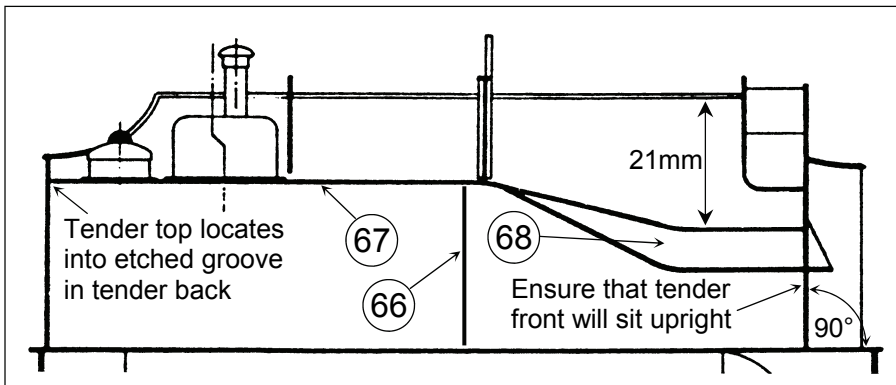

Now pull coal space hopper upwards and tack solder into place, adjusting the coal space to get the best fit as you go. Once happy with the shape and fit solder solid, filling all gaps with solder. Now check the front end to ensure that the tender front (part 69) will sit upright and square. If necessary file back the front of the coal space using a sharp flat file to achieve this.

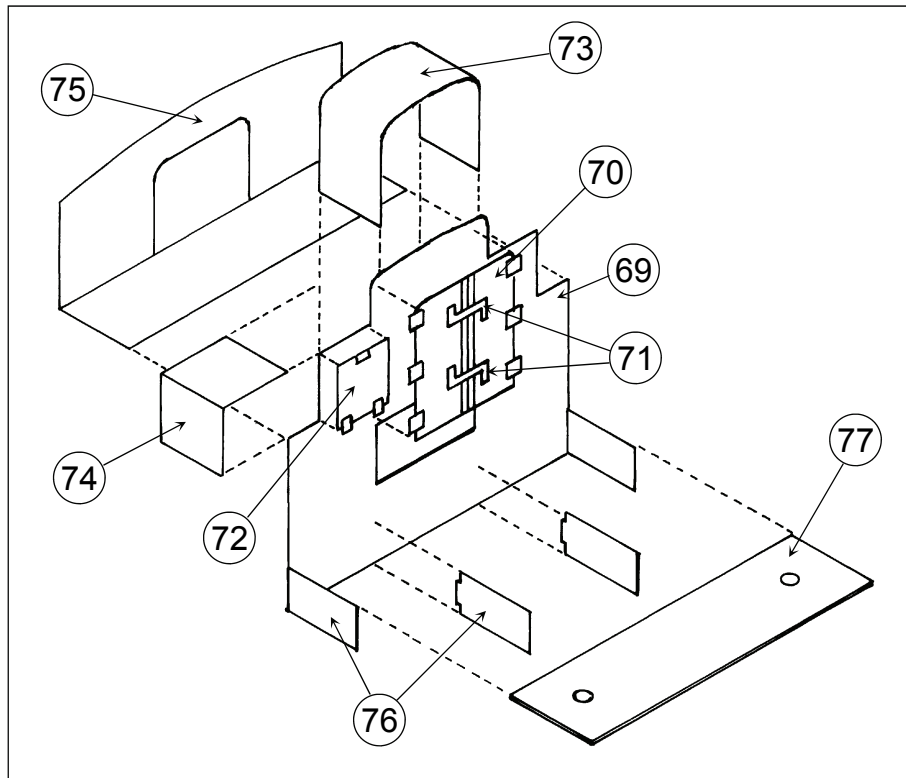

4. I find that it is best to assemble and detail the tender front before fitting into place. Take the front bulkhead (part 69) and fit the fireman's tunnel doors (part 70). Then solder the door catch detail overlays (parts 71) over the raised outlines. Fit the tool box door detail overlays (parts 72) slightly inboard of the corner edges.

7. Take the chassis side frames (parts 96) and open out the axle holes to take the turned bearings. Form up the frame spacers (parts 97) and then lay a side frame onto a flat surface with the top edge of the frame overhanging slightly. Solder the spacers to the side frame. Fit the second side frame tacking into place at the centre spacer. Check that the second side frame is in exactly the right position and that the two frames are exactly opposite each other. Then starting at the centre spacer and working outwards to the end of the frames solder the spacers solid. Fit bearings and wheels, packing out the outer bearings to reduce side play, but fit the centre bearings hard against the frames for maximum side play. I pass an oiled axle through the bearings as I solder them into place to ensure that they are aligned correctly. It is also a good idea to ream out the centre bearings slightly oversize to allow the wheels to follow any humps in your track.

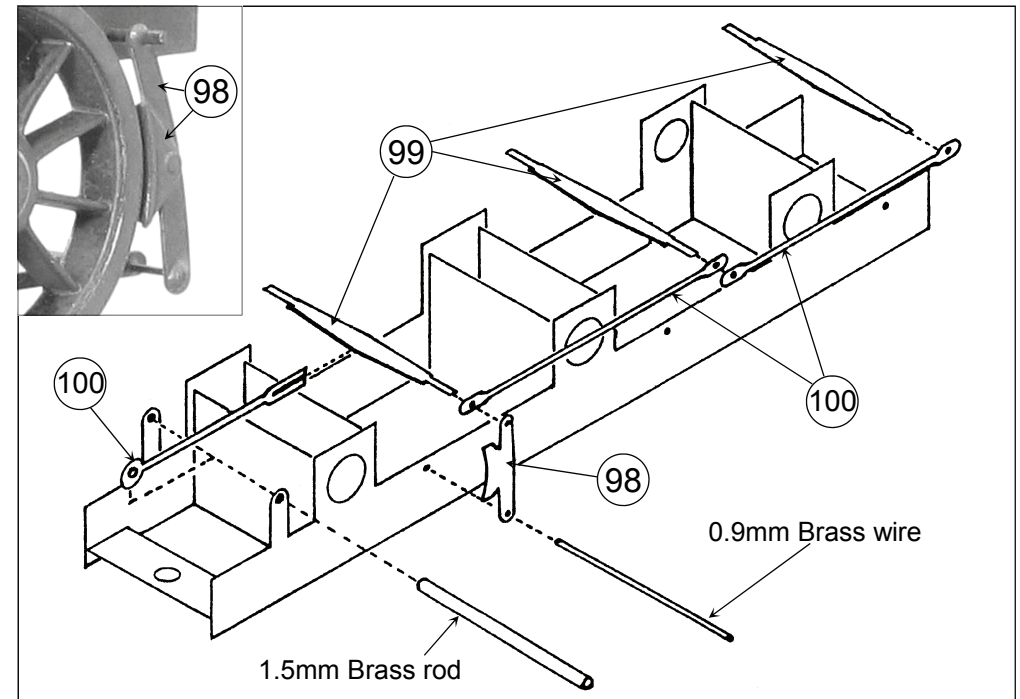

Take the brake blocks and hangers (parts 98) and soldering the blocks to the hangers, make up three L/H and three R/H. Thread three lengths of 0.9mm brass wire across the chassis and locate brake blocks onto this by spot soldering so that the brake blocks are just clear of the wheels. Take the brake cross shafts (parts 99) and pull rods (parts 100) and after threading the ends of the pull rods over the ends of the cross shafts spring the cross shafts between the brake hangers. Working from the rear to the front fit the single front pull rod last by passing an overlong length of 1.5mm brass rod through the brackets on the chassis side frames. Solder all joints solid making any slight adjustment required as you go. Snip off and file square the projecting ends of the brass wire and cross shafts. Cut down the projecting ends of the 1.5mm brass rod so that it will just fit between the tender outer side frames.

Take the steps (parts 93) and note that there are two different profiles for front and back and that they will be handed for L/H and R/H sides. The two etched rebates are to appear on the outside face. Fold the top backwards through 90° this will fit hard against the side frame and space the steps outwards by the correct distance. If the model is to receive rough handling you can solder a length of 0.9mm brass wire down the centreline on the back to provide reinforcing. Solder the steps solidly into place to the underside of the footplate and hard against the buffer beams. Fold the back of the step treads (parts 94) through 90° and bend up the two outer corners slightly, this was probably a safety feature. Solder the treads solidly into the etched rebates.

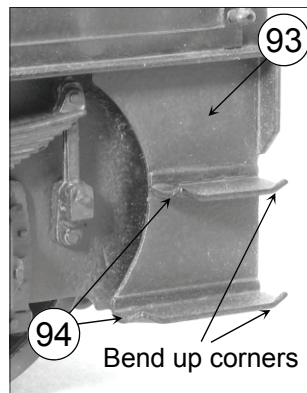

Fold a set in each guard iron (parts 95) using the etched marks as guides. Solder into the slots on the underside of the footplate. Tweak the folds on the guard irons with long nosed pliers to achieve a distance of 32mm (track gauge) apart and reinforce the fold lines with solder.

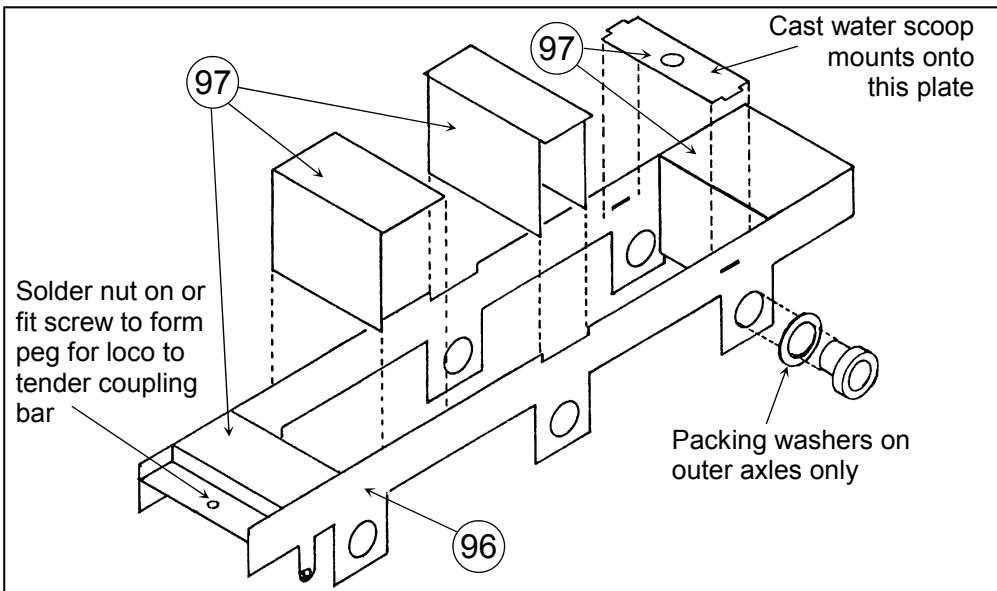
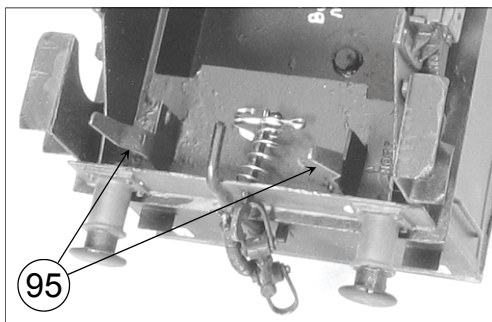
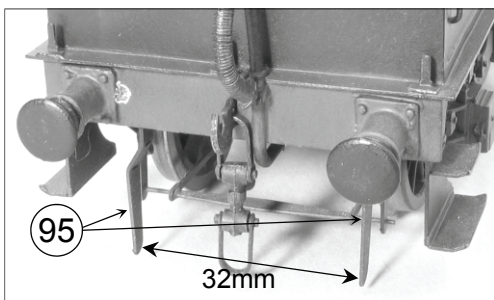

Place the front bulkhead face down and form up the fireman's tunnel (part 73) to match the profile of the etched groove. This requires a gentle radius at the top and two tight radii to bring down the two sides. To help form the tight radii I have provided half etched sections and these should be on the inside. There are also marks to indicate the centre point at the top and these should be helpful in forming each side equally. Once happy with the forming solder into place but ensure that the lower etched groove that runs across the bulkhead remains clear. Then fold the two toolboxes (parts 74) through 90° and solder into the etched grooves of the outer corners. It may be necessary to file the ends to achieve a correct fit and again ensure that the lower etched groove remains clear. Now fold the coal space front (part 75) through 90° and solder into place locating into the lower etched groove. Now fit the tender front into place between the tender sides.

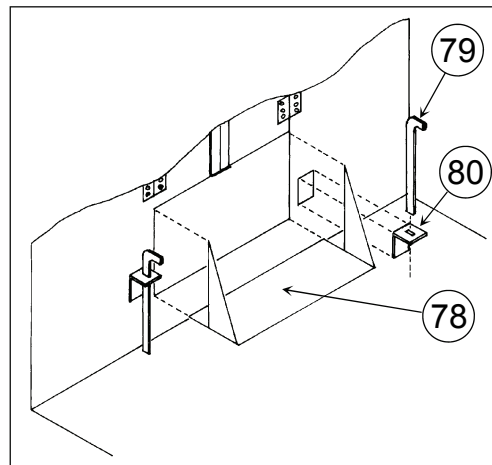

Fit the four supports (parts 76) ensuring that they are all upright and parallel, then fit the fireman's platform (part 77) hard up against the bulkhead. The ends may require slight filing to achieve a snug fit between the tender sides. Form up and fit the coal hole surround (part 78) then the operating handles (parts 79) and brackets (parts 80). The brackets are folded through 90° and located into the etched rebates on the bulkhead and the handles are passed through the slots and the ends spot soldered to the fireman's platform. I think these handles operated the tender to loco water cocks.

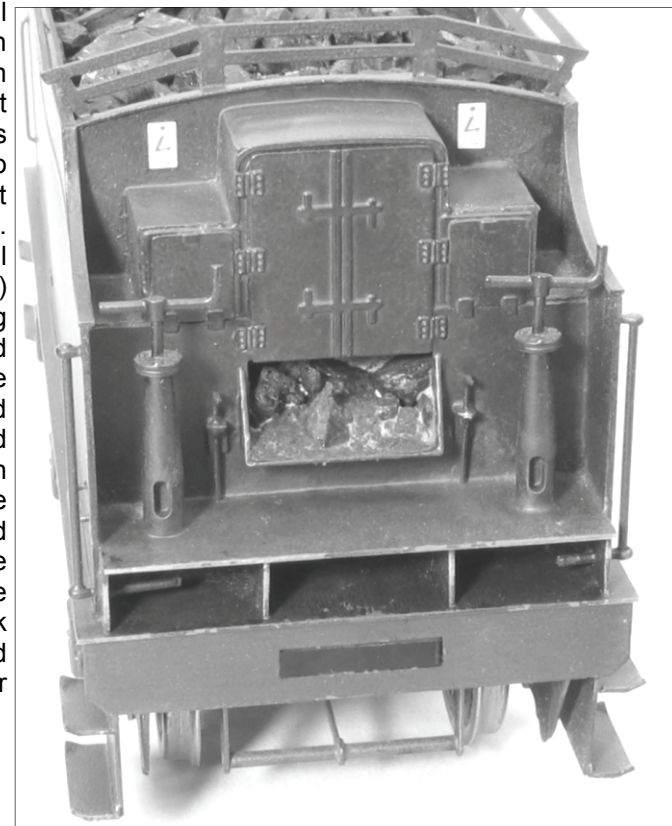

5. Fit the rear coal space bulkhead (part 81) into the slots on the tender top. Fit the reinforcing angles (parts 82) locating into the slots on the bulkhead and fit the rivet detail overlays (parts 83) into each corner and against the reinforcing angles.

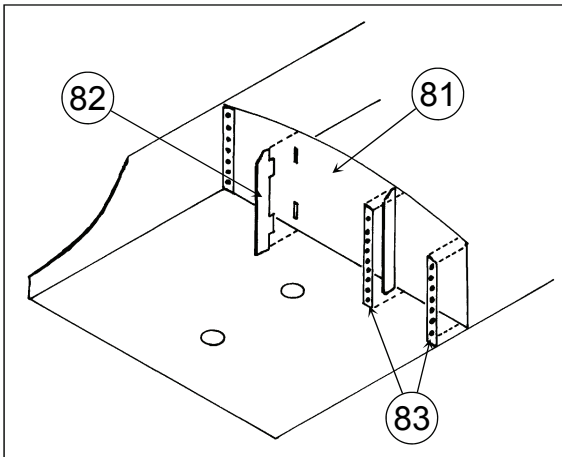

Now fit the top beading strips (parts 84). These strips fit by slotting the half etched groove over the top of the sides and bulkheads. Fit the tender side beading strips first then the strips across the tender back and both bulkheads. The strips that run across will need their ends trimming back slightly to be a snug fit between the side beading. Place a spot of solder onto the top surface at the beading joints and then blend in with a file.

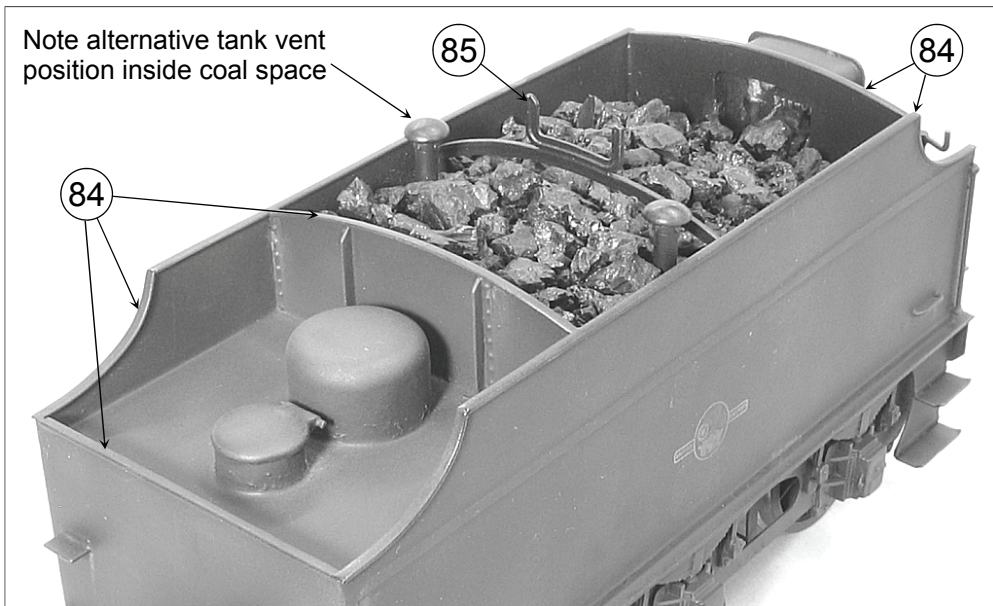

Solder back to back the two parts of the fire iron supports (parts 85) and fit into slots on tender top. Fit the side coal rails (parts 86) and front and rear coal rails (parts 87). I find it best to first tack solder the side coal rails into place setting their position by eye. Fit the end rails adjusting the side rails to match at the corners. Then check all round to ensure that the rails look right to the eye and solder solid. Then trim back and tidy up the corners. Then fit the front and rear coal rail reinforcing angles (parts 88) locating these into the half etched grooves.

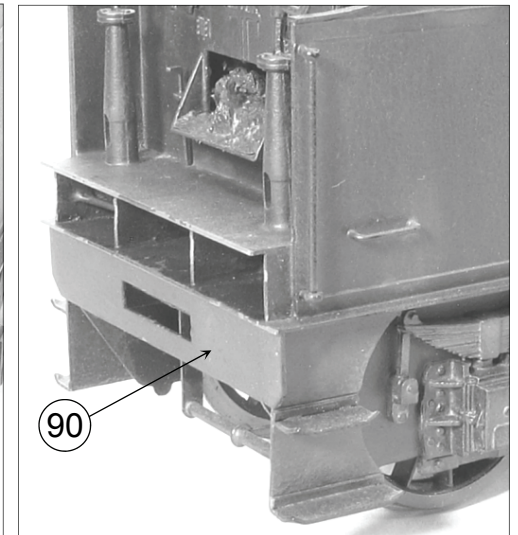
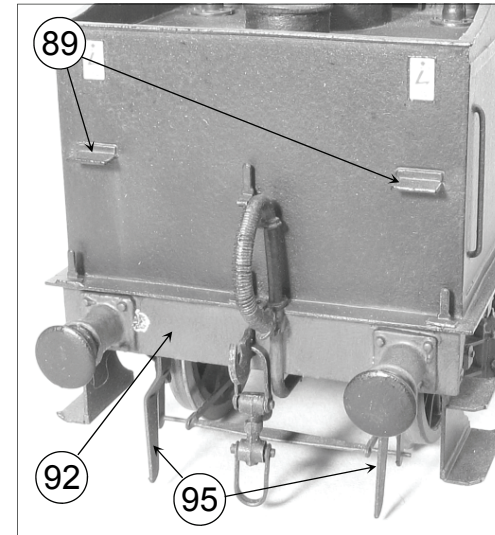
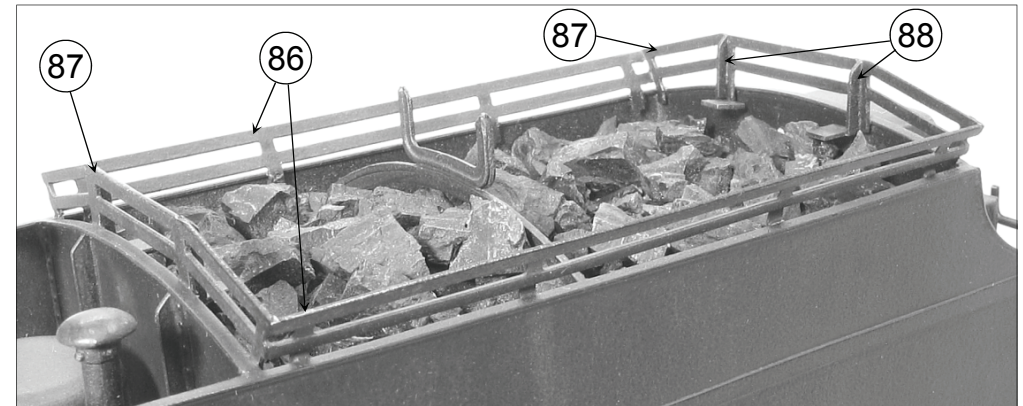

6. Fold the tender back steps (parts 89) through 90° and solder into half etched rebates. Fit the front drag beam (part 90) locating into the half etched groove on the underside of the footplate. Emboss bolt heads on the tender frames (parts 91) and fit into slots on footplate underside so that the end is hard against the front buffer beam. Fit the rear buffer beam (part 92) tight up against the ends of the frames.

